

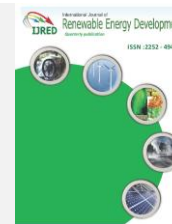

Contents list available at IJRED website

Int. Journal of Renewable Energy Development (IJRED)

Journal homepage: www.ijred.com



Design and Performance Analysis of a Biodiesel Engine Driven Refrigeration System for Vaccine Storage

W. Kamsuk, D. Damrongsak*, and N. Tippayawong

Department of Mechanical Engineering, Faculty of Engineering, Chiang Mai University,

Chiang Mai 50200, THAILAND

Article history:

Received March 21, 2013
Received in revised form April 28, 2013
Accepted May 05, 2013
Available online

ABSTRACT: A compact, stand-alone, refrigeration module powered by a small biodiesel engine for vaccine storage in rural use was proposed. The engine was of single cylinder, four-stroke, direct injection with displacement of 0.296 cm³ and compression ratio of 20:1. The refrigeration system was modified from an automotive vapor compression system. The system performance was analytically investigated. From the simulation, it was found to have acceptable operation over a range of speeds and loads. Performance of the system in terms of fuel consumption and torque tended to decrease with an increase in engine speed. The modular system was able to operate at cooling loads above 4.6 kW, with proper speed ratio between the engine and the compressor. Overall, primary energy ratio of the refrigeration was found to be maximum at 0.54.

Keywords: automotive refrigeration, biomass, small engine, vaccine storage, thermal engineering

1. Introduction

Vaccination is very important in disease prevention for public health. Storage of vaccines is crucial, especially in rural areas. The vaccines must be stored at proper temperature, usually at 0-8 °C. For remote areas where national power grid connection is not available, the storage of vaccine can be a tremendous challenge. It must be transported from nearby storehouses to be utilized, facing possible difficulty. If the region is able to keep its own vaccine, it will be more effective in preventing the diseases. In these areas, power must be obtained from distributed generation, possibly using engine-driven generator set.

Thailand has great potential to produce biodiesel for utilization in diesel engines. In rural areas, the power may be generated using biodiesel engine or using engine to operate refrigeration system. Refrigeration system is important for storage of vaccines. It may be powered by solar energy, hybrid solar-assisted adsorption cooling unit or an engine driven system.

Coronado *et al.* (2009) studied ecological efficiency of internal combustion engines by use of biodiesel. Its emissions were cleaner than diesel fuel. In India,

Agarwal (2007) utilized biodiesel for internal combustion engines and confirmed that biodiesel can be used in engine without further modification. Jiangzhou *et al.* (2002) used a cabin adsorption air-conditioner for cooling system, employing zeolite-water as working pairs. It was driven by the waste heat from the exhaust gas of engines. Refrigeration output performances under adiabatic and cooling conditions were analyzed and it was found that regenerator can continuously and steadily provide refrigeration capacity during the desorption phase. In Malaysia, Abdullah *et al.* (2011) used automobile adsorption air-conditioning system using oil palm biomass. High adsorption performance at low cost was obtained. Damrongsak and Tippayawong (2010) investigated the use of small biogas engine to drive the automotive vapor-compression air-conditioning system. The modular system was found to operate with high coefficient of performance (COP). Hammad and Habali (2000) reported a solar energy powered absorption refrigeration cycle using aqua-ammonia solution for vaccine cabinet. Refrigeration COP was reported to range between 0.5 and 0.65. Dawoud (2007) used hybrid adsorption cooling unit for vaccine storage, utilizing solar energy as a main power

*Corresponding Author: Tel: +6653944146 Ext 964
Email: detddd@gmail.com

supply and a gas burner as an alternative power supply. COP of 0.28 was obtained. Rodjananugoon (2006) considered potential of biodiesel production in Thailand. It was shown that the potential of producing biodiesel in Thailand was very promising.

In this work, attempt was made to propose a practical biodiesel engine driven refrigeration system for vaccine storage. Performance of the system was analytically simulated.

2. Design Concept

2.1 Compact refrigeration module

The compact refrigeration module consists of three systems, namely, a vaccine storage, an automotive air-conditioner, and a biodiesel engine. The automotive air-conditioner is directly coupled to the biodiesel engine, as shown in Fig. 1.

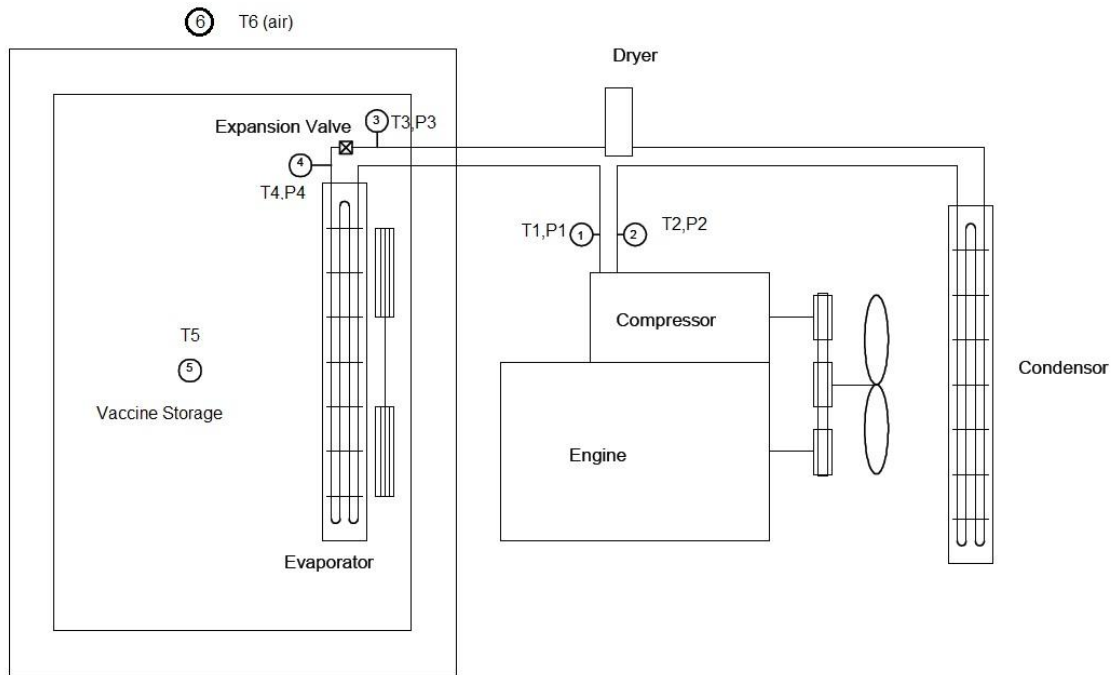

Fig.1 Schematic of vapor-compression air-conditioning system driven by biodiesel engine

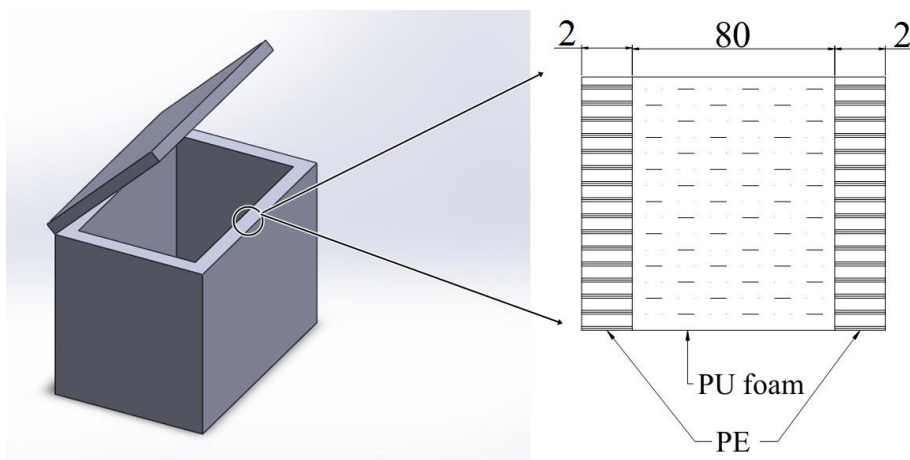

Fig.2 Vaccine storage

2.2 Vaccine storage

The storage is a closed container with thick insulation made from polyurethane (PU) foam and polyethylene (PE). Thicknesses of PU foam and PE wall are 80 and 20 mm, respectively. The internal volume of storage is set to be 0.1 m³, shown in Fig. 2.

2.3 Automotive air-condition system

The refrigeration unit used is modified from original components of an automotive a vapor-compression air-conditioning system. It consists of a compressor, a condenser, an expansion valve and an evaporator, with oil cooler and oil separator. The compressor used is of low cost, piston type. The condenser and evaporator exchange heat cross flow of air streams. The expansion valve is of thermostatic type. In this study, R-134a is chosen to be used as refrigerant. When the refrigerant passes through the indoor coil acting as an evaporator, it absorbs heat from the fan driven air stream, thereby providing a cool air stream. After compression, the refrigerant enters the outdoor coil and rejects heat into another air stream. The automotive air-conditioning system can work in a refrigeration cycle.

2.4 Biodiesel engine

The simulation engine used is Kipor model KM 178 F. It is of in-line, single cylinder, four-stroke, air-cooling, and direct injection. Bore and stroke are 78 and 62 mm, respectively. Displacement is 0.296 cm³. This engine has compression ratio of 20:1. When biodiesel is used as a fuel, the engine can work well.

3. Performance Analysis

Simulation of performance of the vapor-compression air-conditioning system driven by the biodiesel engine is divided into four sections. Initially, the storage, the engine, and the air-conditioning system are evaluated separately for individual performance. Afterward, study is carried out for the integrated unit.

3.1 Storage model

For heat transfer calculation, the cooling load is calculated from (Encropera *et al.* 2007)

$$Q_{cooling} = Q_{storage} + Q_{loss} \tag{1}$$

$$Q_{storage} = m_s c_p \frac{dT}{dt} \tag{2}$$

$$Q_{loss} = U A dT_{LM} \tag{3}$$

$$U = \frac{1}{R_{tot}} \tag{4}$$

$$R_{tot} = \frac{1}{h_{ai}} + \frac{L_1}{k_1} + \frac{L_2}{k_2} + \frac{L_3}{k_3} + \frac{1}{h_{ao}} \tag{5}$$

$$dT_{LM} = \frac{(dT_1 - dT_2)}{\ln\left(\frac{dT_1}{dT_2}\right)} \tag{6}$$

where m_s is mass of vaccine, c_p is specific heat of vaccine, dT is change in vaccine temperature from start and end, dt is charging time, A is heat transfer area of vaccine storage, h_{ai} and h_{ao} are convection heat transfer coefficient for indoor and outdoor, L_1 , L_2 , and L_3 are thicknesses of insulation, k_1 , k_2 , and k_3 are thermal conductivities of insulation, dT_1 is difference between indoor and outdoor temperature in start, and dT_2 is difference indoor and outdoor temperature in end.

3.2 Automotive air-conditioning system model

The air-conditioning system is studied to determine the proper speed of compressor and power requirement to drive the compressor. The speed of compressor is varied between 1000 and 3000 rpm. These data are subsequently used to determine the heat removal from the evaporator or the cooling capacity ($Q_{cooling}$), the COP, and the power required to drive the compressor (W_{comp}). All data are taken when the system is under steady state condition. Performance curve of compressor is shown in Fig. 3.

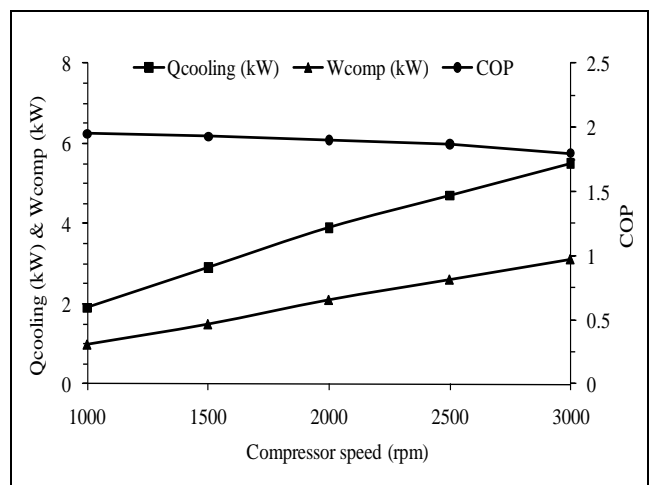

Fig.3 Performance curve of compressor, adapted from SADEN International (2008)

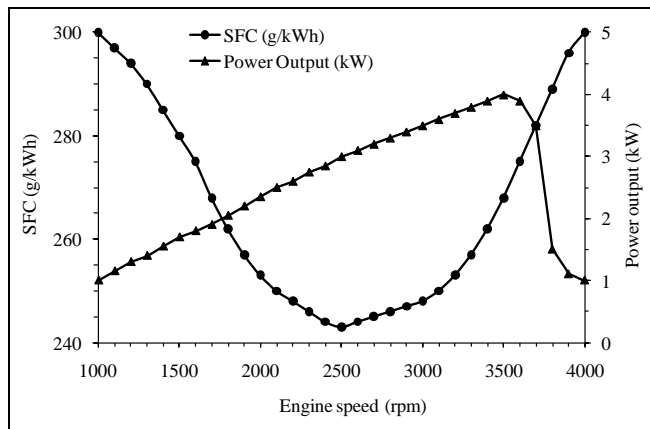

Fig.4 Performance curve of engine, adapted from Kipor Power (2010)

3.3 Biodiesel engine model

A series of study is conducted to evaluate biodiesel engine performance on stand-alone mode of operation with varying speeds and loads. In the study, engine speed is varied between 1500 and 4000 rpm. Measurements on engine power output, torque, and specific fuel consumption are performed at the throttle valve openings of 100%. Efficiency of the biodiesel engine, defined as the ratio of the engine power output to input power from the biodiesel, is derived from the following expression (Pulkrabek 2003):

$$\eta = \frac{P_{\text{engine}}}{V_f \text{LHV}_f} \quad (7)$$

$$V_f = P_{\text{engine}} \text{SFC} \quad (8)$$

P_{engine} and SFC data are obtained from performance curve of the engine, shown in Fig. 4.

3.4 Integrated model

The air-conditioning system is coupled to the biogas engine in a compact module. The studies are performed to investigate the entire system performance in terms of the cooling capacity and the primary energy ratio (PER), defined as the ratio of the required output to primary energy demand:

$$\text{PER} = \frac{Q_{\text{cooling}}}{V_f \text{LHV}_f} \quad (9)$$

with varying speed ratio (SR) of the engine and compressor from:

$$\text{SR} = \frac{\text{Engine speed}}{\text{Compressor speed}} \quad (10)$$

Calculation procedure is shown in Fig. 5. Performance analyses are based on the following input data, shown in Table. 1.

Table 1
Input data for the design analysis

S/No	Item	Symbol	Units	Value
1	Mass of vaccine	m_s	kg	9.97
2	Specific heat of vaccine	c_p	J/kg-K	4180
3	Change in vaccine temperature from start and end	dT	K	30
4	Charging time	dt	sec	1800
5	Heat transfer area of vaccine storage	A	m^2	1.25
6	Convection heat transfer coefficient indoor	h_{ai}	W/m^2K	25
7	Convection heat transfer coefficient outdoor	h_{ao}	W/m^2K	200
8	Thickness of PE	L_1	m	0.002
9	Thickness of PU foam	L_2	m	0.08
10	Thickness of PE	L_3	m	0.002
11	Thermal conductivity of PE	K_1	$W/m-K$	0.3
12	Thermal conductivity of PU foam	K_2	$W/m-K$	0.03
13	Thermal conductivity of PE	K_3	$W/m-K$	0.3
14	Difference temperature indoor and outdoor in start	dT_1	K	30
15	Difference temperature indoor and outdoor in end	dT_2	K	22
16	Cooling capacity	Q_{cooling}	kW	4.6
17	Power required to drive the compressor	W_{comp}	kW	2.7
18	Engine power output	P_{engine}	kW	3
19	Specific fuel consumption	SFC	g/kW-h	243
20	Lower heating value	LHV _f	kJ/kg	420000
21	Engine speed	-	RPM	2500
22	Compressor speed	-	RPM	2500

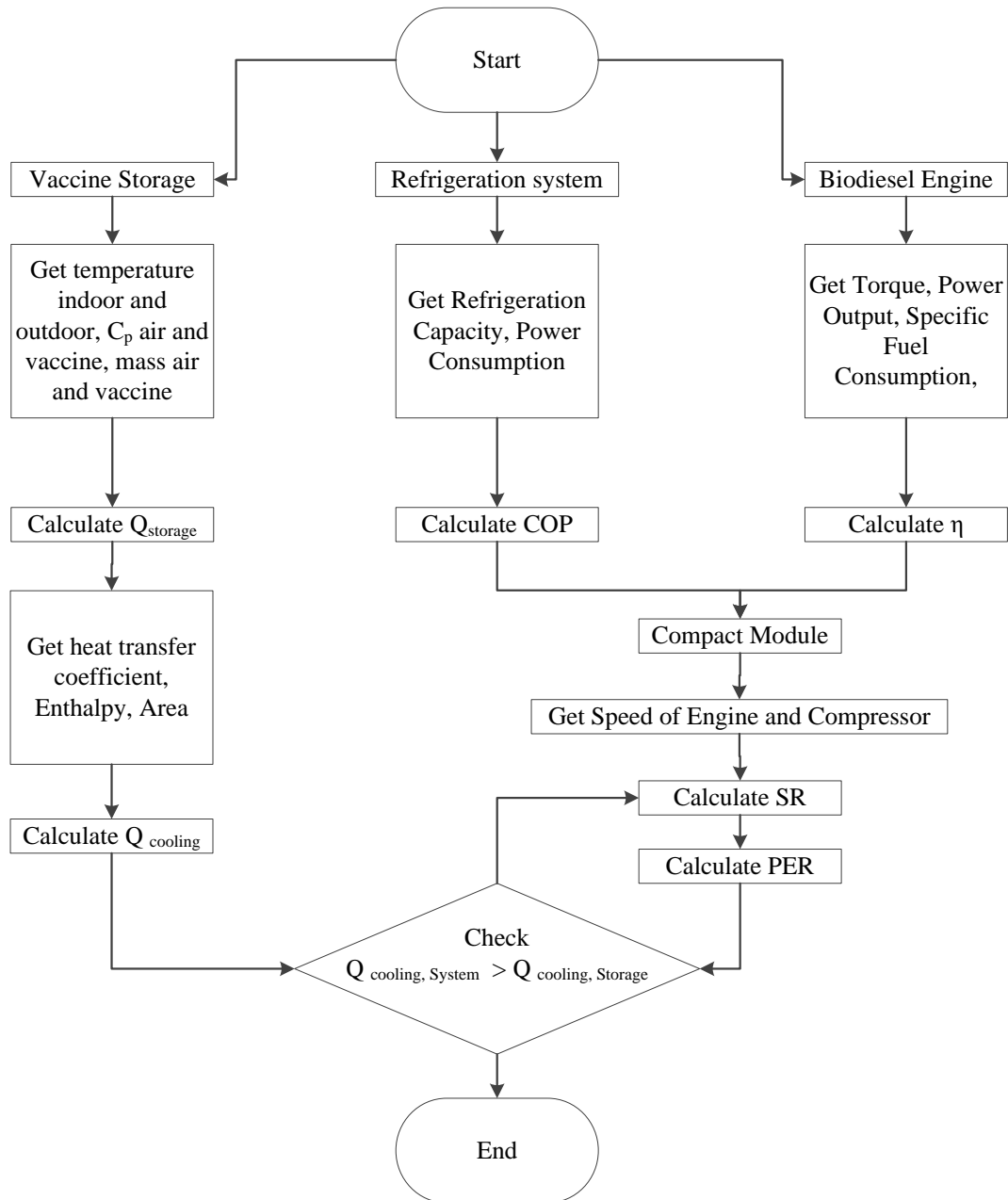

Fig.5 Flow chart for performance calculation of the compact refrigeration module

4. Results and Discussion

4.1 Heat transfer in storage

The cooling capacity of the storage is shown in Figs. 6 and 7. The calculated cooling load of storage was found to decline with time from maximum at 2000 – 2100 W, and decline steady to an asymptotic value of about 300 W.

4.2 Engine performance

The simulation of the biodiesel engine provides the performance curves in terms of power output, torque, specific fuel consumption and efficiency with respect to

the engine speed, shown in Figs. 8 – 11. The engine torque was found to initially increase with engine speed, reach maximum around 2000–3000 rpm and decline as the speed approaches 4000 rpm. Similar characteristics were also observed for the engine efficiency. The power output was found to initially increase with engine speed, reach maximum around 3000–3500 rpm and decline as the speed approaches 4000 rpm. The specific fuel consumption was found to initially decline with engine speed, reach minimum around 2000–3000 rpm and increase as the speed approaches 4000 rpm. It should be noted that high power output and efficiency occurred at high engine speeds for the small engine. The maximum torque was

13 N-m at the engine speed of 2500 rpm. The maximum power was 4 kW at the engine speed of 3500 rpm. The lowest specific fuel consumption of 243 g/kWh was observed at 2500 rpm, and the best engine efficiency was 35.3% at the same engine speed.

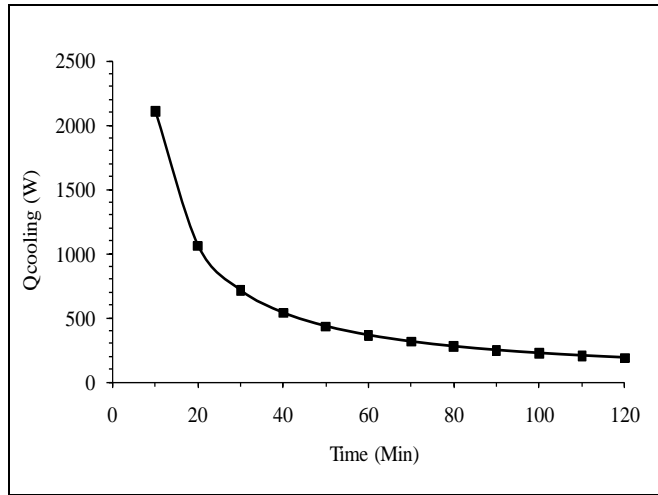

Fig. 6 Variation of cooling capacity with operation time

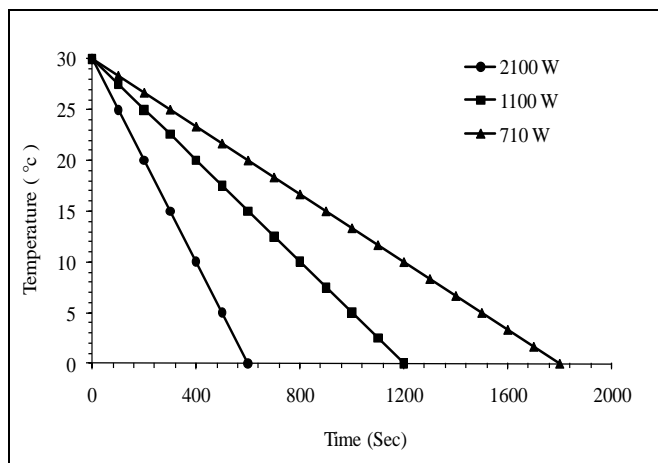

Fig. 7 Temperature of storage as a function of time and $Q_{cooling}$

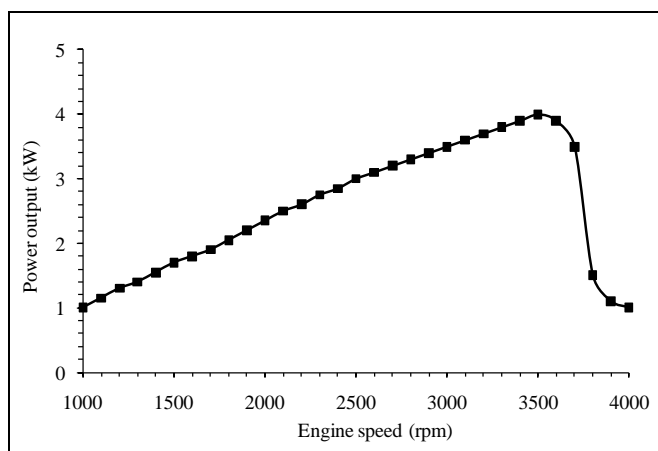

Fig. 8 Variation of power output with engine speed, adapted from Kipor Power (2010)

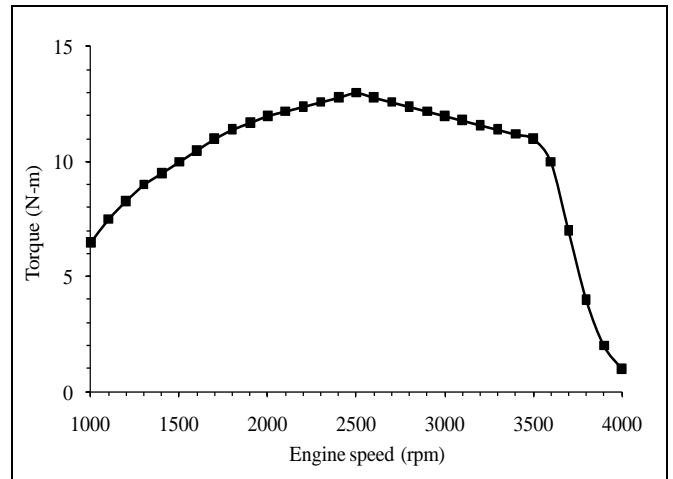

Fig. 9 Variation of torque with engine speed, adapted from Kipor Power (2010)

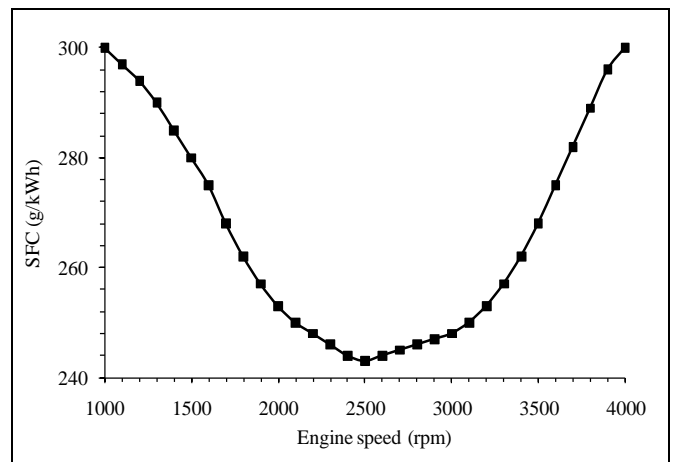

Fig. 10 Variation of SFC with engine speed, adapted from Kipor Power (2010)

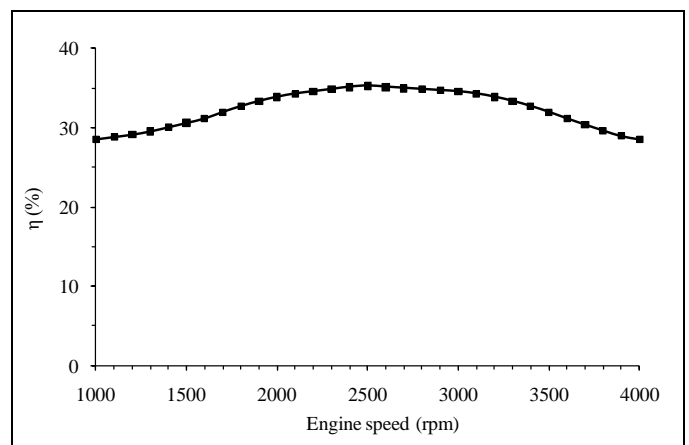

Fig. 11 Variation of efficiency with engine speed, adapted from Kipor Power (2010)

4.3 Refrigeration performance

Performance curve of the vapor compression refrigeration system is illustrated in Figs. 12 and 13.

The cooling capacity and the power required to drive the compressor are plotted against the compressor speed. As anticipated, the cooling capacity was found to increase with speed. It changed from below 0.55 to 6.1 kW as the compressor speed increased from 1000 to 3000 rpm. Regarding the compressor power requirement, a linear ascending trend with speed was observed from below 0.35 to 3.7 kW as the compressor speed increased from 1000 to 3000 rpm. COP value of the vapor compression refrigeration system was found to increase with compressor speed, reach maximum around 1000–2000 rpm and decline as the speed approaches 3000 rpm. The highest COP was 1.87 at compressor speed of 1500 rpm.

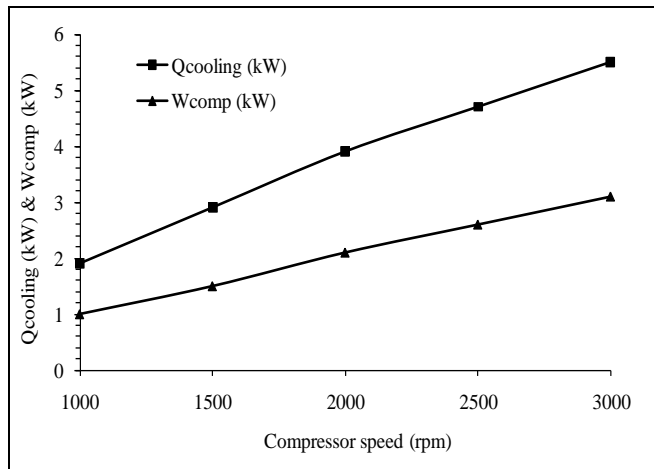

Fig. 12 Variation of cooling capacity at evaporator and compressor power requirement with engine speed, adapted from SADEN International (2008)

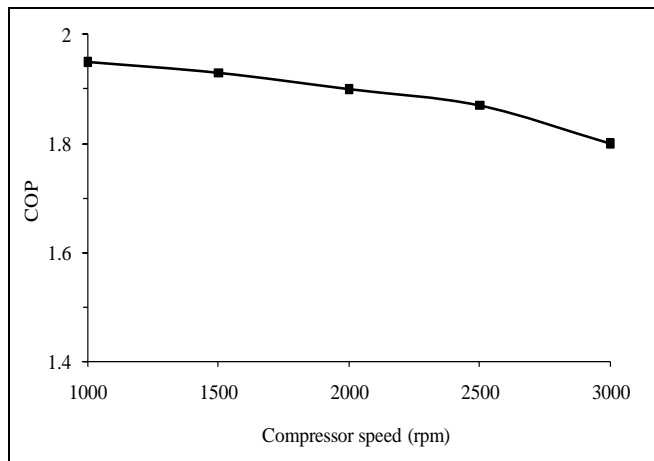

Fig. 13 Variation of COP with engine speed, adapted from SADEN International (2008)

4.4 Compact module performance

The refrigeration system driven by the biodiesel engine is simulated for a range of SR. Fig. 14 shows the effects of the engine speed and SR on the refrigeration capacity of the system. The cooling capacity was found to reduce with the reducing speed and the increasing SR from 1.0

to 3.0. Fig. 15 shows the PER of the compact module over a range of the engine speed. The PER was found to initially increase with engine speed, reach maximum around 2500–3000 rpm and decline as the speed approaches 3500 rpm. The PER appeared to decrease with an increase in SR.

It is clear that the biodiesel engine can be used to run the refrigeration systems with acceptable operation over a range of speeds and loads. However, when the automotive air-conditioning unit is coupled with the biodiesel engine, it is imperative that the optimal operating condition should be determined for both units. It is identified that the biodiesel engine may operate at engine speed of 2500 rpm for the best engine efficiency of 35.3%, the lowest specific fuel consumption of 243 g/kWh and identified SR of 1 for the best PER of 0.54. In turn, the refrigeration unit must operate the compressor speed at 2500 rpm for cooling capacity of 4.6 kW. The biodiesel engine is preferred to operate at part load so that the modular system has a high cooling capacity.

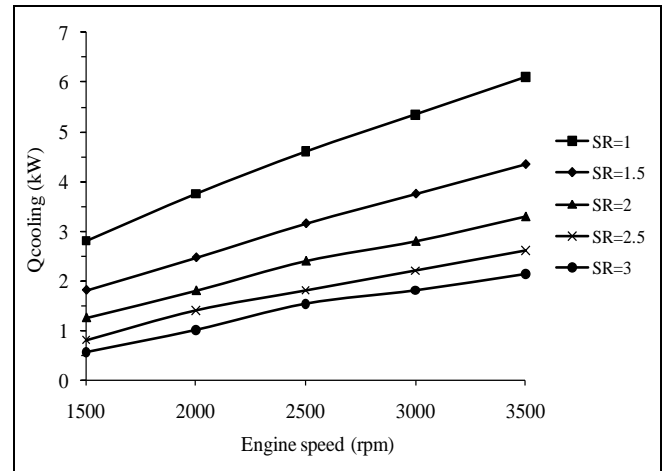

Fig. 14 Cooling capacity of the compact module system as a function of engine speed and SR

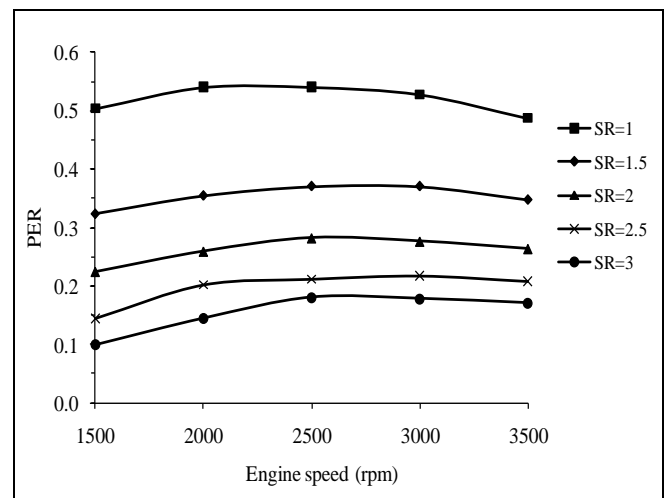

Fig. 15 Performance of the compact module system as a function of engine speed and SR

5. Conclusion

A compact module refrigeration system driven by a small biodiesel engine is proposed. Analytical investigation of the module performance has been carried out in terms of cooling capacity, PER, thermal efficiency and fuel consumption. The simulation results show that a range of the desired refrigerating capacity of the compact module can be achieved by means of varying engine speeds. For engine speed of 2500 rpm, and identified SR of 1, the best engine efficiency of 35.3%, the lowest specific fuel consumption of 243 g/kWh may be obtained at SR of 1, with cooling capacity of 4.6 kW, the best PER of 0.54. The compact module offers an alternative option for vaccine storage applications in remote areas.

Acknowledgement

Financial support from the Faculty of Engineering, Chiang Mai University is gratefully acknowledged.

References

Abdullah, M. O., Tan, I. A. W. & Lim, L. S. (2011) Automobile adsorption air-conditioning system using oil palm biomass-based activated

carbon: A review. *Renewable and Sustainable Energy Reviews*, 15, 2061–2072.

Agarwal, A. K. (2007) Biofuels (alcohols and biodiesel) applications as fuels for internal combustion engines. *Progress in Energy and Combustion Science*, 33, 233–271.

Coronado, C. R., Carvalho Jr., J. A., Yoshioka, J. T. & Silveira, J. L. (2009) Determination of ecological efficiency in internal combustion engines: The use of biodiesel. *Applied Thermal Engineering*, 29, 1887–1892.

Damrongsak, D., & Tippayawong, N. (2010) Experimental investigations of an automotive air-conditioning system driven by a small engine. *Applied Thermal Engineering*, 30, 400-405.

Dawoud, B. (2007) A hybrid solar-assisted adsorption cooling unit for vaccine storage. *Renewable Energy*, 32, 947–964.

Hammad, M. & Habali, S. (2000) Design and performance study of a solar engine powered vaccine cabinet. *Applied Thermal Engineering*, 20, 1785-1798.

Incropera, F. P., Dewitt, D. P., Bergman, T. L. & Lavine, A. S. (2007) *Introduction to Heat Transfer*. Wiley Asia, Singapore.

Jiangzhou, S., Wang, R. Z., Lu, Y. Z., Xu, Y. X. & Wu, J. Y. (2002) Experimental investigations on adsorption air-conditioner used in internal-combustion locomotive driver-cabin. *Applied Thermal Engineering*, 22, 1153-1162.

Kipor Power (2010) KM 178 F Performance. Retrieved December 8th, 2012, www.kipor.com/product/show.aspx?classid=144401061099077632

Pulkrabek, W. W. (2003) *Engineering Fundamental of the Internal Combustion Engine*. Pearson Education Indochina, Bangkok.

Rodjananugoon, J. (2006) *A Potential Study of Biodiesel Production in Thailand*. M.Eng. thesis, Prince of Songkla University, Thailand.

SANDEN International (2008) SD5H11 Performance. Retrieved December 8th, 2012, www.sanden.com.sg/opencms/opencms/sites/default/Sanden/_configuration/Catalogue/Product.jsp?pid=1002